

Nama: ..... Kelas: .....

---

---

**SEKOLAH MENENGAH KEBANGSAAN**

---

---

**PEPERIKSAAN PERCUBAAN SPM TAHUN 2021**

**FIZIK**

**4531/1**

**TINGKATAN 5**

**Kertas 1**

**NOV 2021**

1 ¼ jam

Satu jam tiga puluh

minit

---

---

**JANGAN BUKA KERTAS PEPERIKSAAAN INI SEHINGGAN DIBERITAHU**

1. Kertas peperiksaan ini adalah dalam dwibahasa.
2. Soalan dalam Bahasa Melayu mendahului soalan yang sepadan dalam Bahasa Inggeris.
3. Kalkulator saintifik yang tidak boleh diprogramkan adalah dibenarkan.
4. Sila hitamkan jawapan anda dengan jelas pada Kertas Objektif. Sila padam dengan kemas jika ingin menukar jawapan.

Maklumat berikut mungkin berfaedah. Simbol-simbol mempunyai makna yang biasa.  
*The following information may be useful. The symbols have their usual meaning.*

1	$a = \frac{v-u}{t}$	20	$\frac{1}{f} = \frac{1}{u} + \frac{1}{v}$
2	$v^2 = u^2 + 2as$	21	Pembesar linear, $m = \frac{v}{u}$
3	$s = ut + \frac{1}{2}at^2$		Linear magnification, $m = \frac{v}{u}$
4	Momentum = $mv$	22	$Q = It$
5	$F = ma$	23	Tekanan / Pressure, $p = h\rho g$
6	Daya graviti, $F = \frac{Gm_1m_2}{r^2}$	24	$E = VQ$
	Gravitational force, $F = \frac{Gm_1m_2}{r^2}$	25	$V = IR$
7	Daya memusat $F = \frac{mv^2}{r}$	26	Kuasa / Power, $P = IV$
	Centripetal force, $F = \frac{mv^2}{r}$	27	$g = 9.81 \text{ m s}^{-1}$
8	Pecutan graviti, $g = \frac{GM}{r^2}$	28	$\frac{N_s}{N_p} = \frac{V_s}{V_p}$
	Gravitational acceleration, $g = \frac{GM}{r^2}$	29	Kecekapan / Efficiency = $\frac{I_s V_s}{I_p V_p} \times 100\%$
9	$T^2 = \frac{4\pi^2 r^3}{GM}$	30	$E = mc^2$
10	Halaju lepas, $v = \sqrt{\frac{GM}{r}}$	31	$c = 3.00 \times 10^8 \text{ m s}^{-1}$
	Escape velocity, $v = \sqrt{\frac{GM}{r}}$	32	1 u.j.a = $1.66 \times 10^{-27} \text{ kg}$
11	$\rho = \frac{m}{V}$		1 a.m.u
12	Haba / Heat, $Q = mc\Delta\theta$	33	$eV = \frac{1}{2}mv_{maks}^2$
13	Haba / Heat, $Q = ml$	34	Momentum, $p = \frac{h}{\lambda}$
14	$\frac{pV}{T}$ = pemalar / constant	35	Tenaga foton, $E = hf$
15	$v = f\lambda$		Photon energy, $E = hf$
16	$\lambda = \frac{ax}{D}$	36	$hf = W + \frac{1}{2}mv^2$
17	$n = \frac{\sin i}{\sin r}$	37	$G = 6.67 \times 10^{-11} \text{ N m}^2 \text{ kg}^{-2}$
18	$n = \frac{1}{\sin c}$	38	$h = 6.63 \times 10^{-34} \text{ J s}$
19	$n = \frac{\text{dalam nyata}}{\text{dalam ketara}}$		
	$n = \frac{\text{real depth}}{\text{apparent depth}}$		

1. Antara kuantiti-kuantiti berikut, yang manakah bukan kuantiti asas?  
*Which of the following quantity is not basic quantity?*

- A. Panjang  
*Length*
- B. Masa  
*Time*
- C. Arus elektrik  
*Electric current*
- D. Kuantiti cas  
*Quantity of charge*

2. Rajah 2 menunjukkan situasi di taman permainan.  
*Diagram 2 shows situation in a playground.*



Rajah / Diagram 2

- Apakah pembolehubah dimanipulasikan dan pembolehubah bergerak balas yang sesuai?  
*What is the suitable manipulated variable and responding variable?*

	Pembolehubah dimanipulasikan <i>Manipulated variable</i>	Pembolehubah bergerak balas <i>Responding variable</i>
A.	Jisim ladung <i>Mass of bob</i>	Tempoh ayunan <i>Period of oscillation</i>
B.	Panjang bandul <i>Length of pendulum</i>	Tempoh ayunan <i>Period of oscillation</i>
C.	Kelajuan bandul <i>Speed of pendulum</i>	Panjang bandul <i>Length of pendulum</i>
D.	Tempoh ayunan <i>Period of oscillation</i>	Kelajuan bandul <i>Speed of pendulum</i>

3. Rajah 3 menunjukkan laluan yang dilalui oleh seorang lelaki.  
 Diagram 3 shows the path travelled by a man.

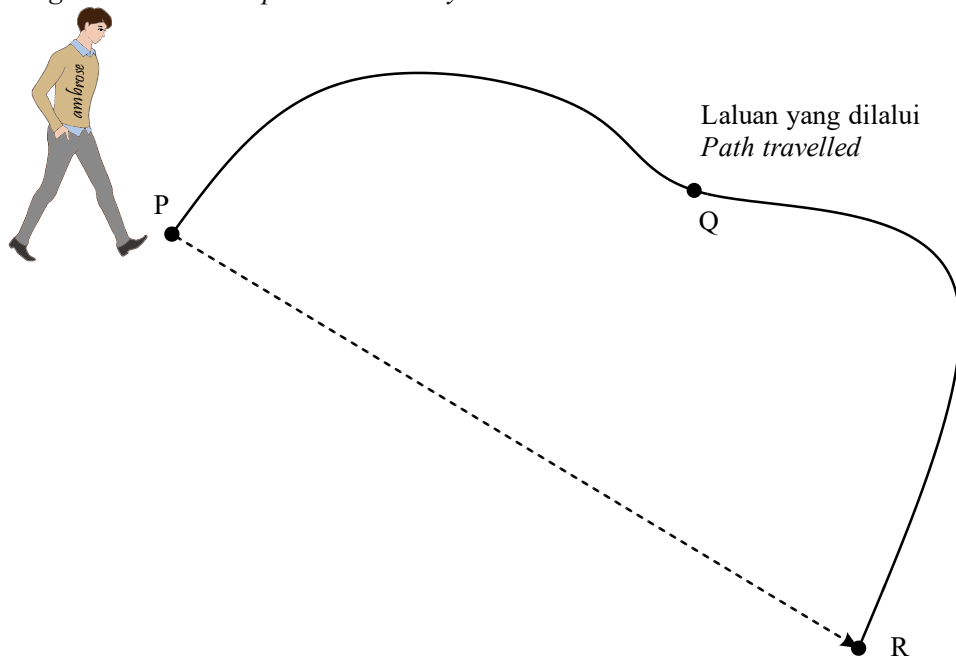

Rajah / Diagram 3

Apakah kuantiti yang boleh ditentukan dari laluan PQR dan PR?  
 What is the quantity can be determine from path PQR and PR?

	PQR	PR
A.	Jarak dan laju <i>Distance and speed</i>	Sesaran dan halaju <i>Displacement and velocity</i>
B.	Sesaran dan halaju <i>Displacement and velocity</i>	Jarak dan laju <i>Distance and speed</i>
C.	Jarak dan laju <i>Distance and speed</i>	Jarak dan laju <i>Distance and speed</i>
D.	Sesaran dan halaju <i>Displacement and velocity</i>	Sesaran dan halaju <i>Displacement and velocity</i>

4. Rajah 4 menunjukkan sebuah kapal terbang sedang berlepas.  
 Diagram 4 shows an aeroplane is take off.

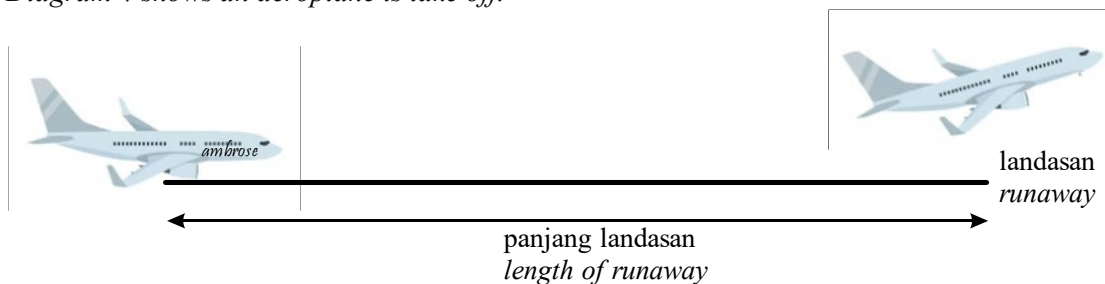

Rajah / Diagram 4

Berapakah panjang landasan bagi sebuah kapal terbang untuk berlepas dengan halaju  $75 \text{ m s}^{-1}$  jika ia boleh memecut  $2.0 \text{ m s}^{-2}$ ?

How long must a runway be for an aeroplane to reach take off velocity  $75 \text{ m s}^{-1}$  if it can accelerate  $2.0 \text{ m s}^{-2}$ ?

- |    |         |    |         |
|----|---------|----|---------|
| A. | 1 000 m | C. | 1 400 m |
| B. | 1 200 m | D. | 2 000 m |

5. Rajah 5 menunjukkan Bola A dan Bola B yang mempunyai jisim yang berbeza. Satu bola mempunyai jisim dua kali ganda berbanding bola yang satu lagi.  
*Diagram 5 shows Ball A and Ball B have different masses. One ball having the mass twice than the other ball.*



Rajah / Diagram 5

Tanpa mengangkat dan menggunakan penimbang, bagaimanakah cara menentukan bola yang mempunyai jisim yang lebih besar?

*Without lifting and weighing, how to determine which ball has greater mass?*

- A. Gerakkan kedua-dua bola dengan daya yang sama, bola yang susah digerakkan mempunyai jisim yang besar kerana inersianya besar  
*Push the balls with the same force, the ball that harder to move has greater mass due to greater inertia*
- B. Gerakkan kedua-dua bola dengan daya yang sama, bola yang menghasilkan pecutan tinggi mempunyai jisim yang lebih besar.  
*Move both the balls with the same force, the ball that having greater acceleration has greater mass*
- C. Putarkan kedua-dua bola, bola yang cepat berhenti mempunyai jisim yang lebih besar.  
*Rotate both balls, the ball that quickly stops has a greater mass*
- D. Gerakkan kedua-dua bola di atas lantai rata, bola yang bergerak lurus mempunyai jisim yang lebih besar  
*Move both balls on a flat floor, a ball moving straight has a greater mass*
6. Rajah 6 menunjukkan tindakan ikut lajak yang dilakukan oleh seorang pemain bola sepak.  
*Diagram 6 shows follow through action by a football player.*

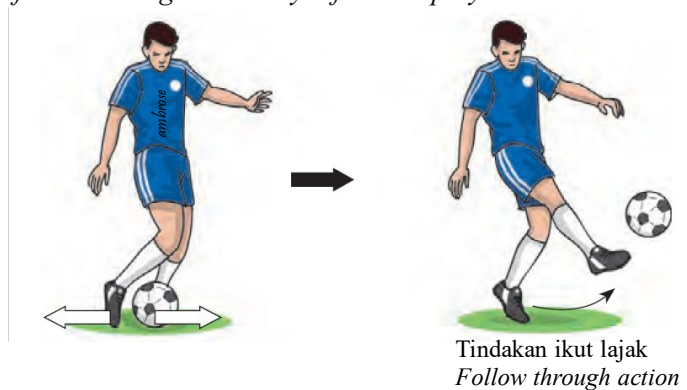

Rajah / Diagram 6

Apakah tujuan tindakan ikut lajak?

*What is the purpose of follow through action?*

- A. Untuk meningkatkan daya impuls  
*To increase the impulsive force*
- B. Untuk meningkatkan impuls  
*To increase the impulse*
- C. Untuk meningkatkan inersia bola  
*To increase the inertia of the ball*
- D. Untuk mengurangkan perubahan momentum bola  
*To decrease the change in momentum of the ball*

7. Sebuah satelit pengimejan radar mengorbit mengelilingi bumi pada ketinggian 500 km. Berapakah nilai pecutan graviti satelit di kedudukan tersebut?  
*A radar imaging satellite orbits around the earth at a height 500 km. what is the value of gravitational acceleration at the position of the satellite?*  
 [  $G = 6.67 \times 10^{-11} \text{ Nm}^2 \text{ kg}^{-2}$ ,  $R = 6.37 \times 10^6 \text{ m}$ ,  $M = 5.97 \times 10^{24} \text{ kg}$  ]
- A.  $9.81 \text{ m s}^{-2}$   
 B.  $9.50 \text{ m s}^{-2}$   
 C.  $8.15 \text{ m s}^{-2}$   
 D.  $8.44 \text{ m s}^{-2}$
8. Rajah 8 menunjukkan sebahagian planet-planet dalam sistem suria.  
*Diagram 8 shows some planets in solar system.*

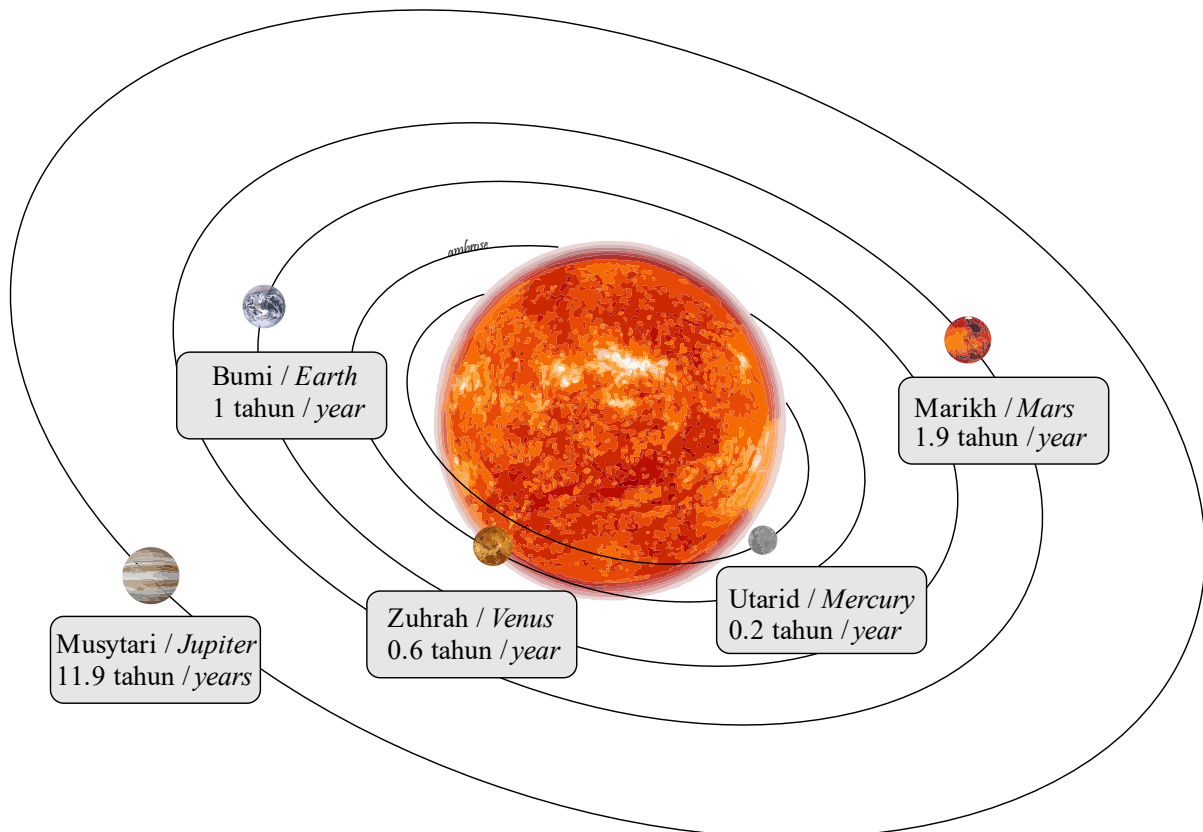

Rajah / Diagram 8

Daripada Rajah 8, apakah kesimpulan yang boleh dibuat?

*From Diagram 8, what is the conclusion can be made?*

- A. Jejari orbit berkadar terus dengan tempoh orbit planet.  
*Radius of orbit is directly proportional with orbital period of planets.*
- B. Kuasa dua jejari orbit berkadar terus dengan kuasa tiga tempoh orbit planet.  
*The square of radius of orbit is directly proportional with the cube orbital period of planets.*
- C. Semakin besar size planet, semakin bertambah tempoh orbit.  
*The greater the size of planet, the greater the period of orbit.*
- D. Kuasa tiga jejari orbit berkadar terus dengan kuasa dua tempoh orbit planet.  
*The cube of radius of orbit is directly proportional with the square orbital period of planets.*

9. Antara pernyataan berikut yang manakah betul tentang satelit geopegun?  
Which of the following statements are correct about geostationary satellite?

I	Tempoh orbit 24 jam <i>Orbital period is 24 hours</i>
II	Berada di atas tempat yang sama di muka bumi <i>Above the same geographical location</i>
III	Digunakan sebagai pengimejan bumi, GPS dan kaji cuaca <i>Used in earth imaging, GPS and weather forecast</i>
IV	Arah gerakan sama dengan arah putaran bumi <i>Direction of motion same as direction of earth rotation</i>

- A. I, II, III  
B. I, II, IV  
C. I, III, IV  
D. II, III, IV
10. Rajah 10 menunjukkan seorang budak berjalan di atas pasir dan seorang budak berjalan dalam air laut.  
Diagram 10 shows a boy walking on the sand and another boy walking in sea water.

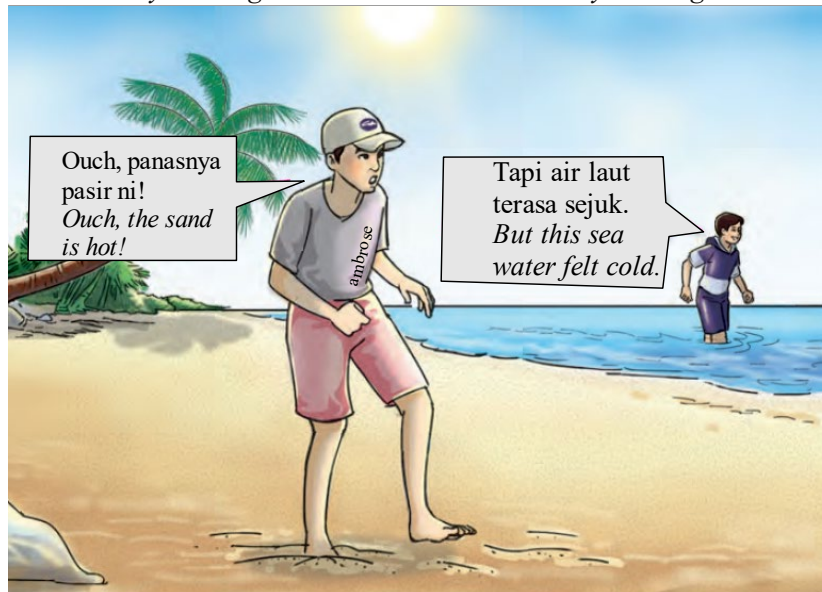

Rajah / Diagram 10

- Pernyataan manakah yang dapat menerangkan situasi dalam Rajah 10?  
Which of the following statement can explain the situation in Diagram 10?
- A. Muatan haba tentu pasir lebih rendah berbanding haba pendam tentu pasir.  
*The specific heat capacity of sand is lower than specific latent heat of sand.*
- B. Haba pendam bagi pasir adalah rendah daripada haba pendam air laut.  
*The latent heat of sand is lower than latent heat of sea water.*
- C. Haba pendam tentu pasir lebih tinggi daripada haba pendam tentu air laut.  
*The specific latent heat of sand is higher than specific latent heat of sea water.*
- D. Muatan haba tentu pasir lebih rendah daripada muatan haba tentu air laut.  
*The specific heat capacity of sand is lower than specific heat capacity of sea water.*

11. Rajah 11 menunjukkan alkohol ditiup berulang kali menggunakan penyedut minuman. Didapati bahawa bahagian luar bikar menjadi sejuk.  
*Diagram 11 shows alcohol is blown repeatedly by using drinking straw. It was found that the outside of the beaker became cold.*

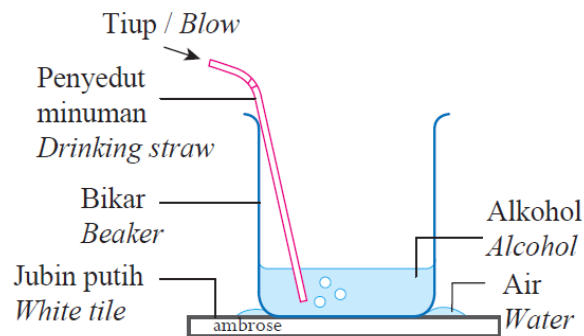

Rajah / Diagram 11

Antara pernyataan berikut yang manakah adalah betul?

*Which of the following statement is correct?*

- A. Penyerapan muatan haba semasa proses penyejatan memberi kesan penyejukan.  
*Absorption of heat capacity during evaporation gives cooling effect.*
- B. Penyerapan haba pendam semasa proses penyejatan memberi kesan penyejukan.  
*Absorption of latent heat during evaporation process gives cooling effect.*
- C. Alkohol mempunyai muatan haba tentu yang rendah.  
*Alcohol has low specific heat capacity.*
- D. Alkohol mempunyai haba pendam tentu yang rendah.  
*Alcohol has low specific latent heat.*
12. Rajah 12.1 dan Rajah 12.2 menunjukkan dua picagari yang serupa dengan muncungnya ditutup. Apabila isipadu udara terperangkap dalam picagari adalah 3 ml, tekanannya adalah  $1 \times 10^5 \text{ Pa}$ . Kemudian ombok ditolak perlahan-lahan sehingga isipadunya 0.45 ml.  
*Diagram 12.1 and Diagram 12.2 shows two identical syringes with their nozzles closed. When the volume of air trapped in the syringe is 3 ml, the pressure is  $1 \times 10^5 \text{ Pa}$ . Then the piston is pushed slowly until its volume is 0.45 ml.*

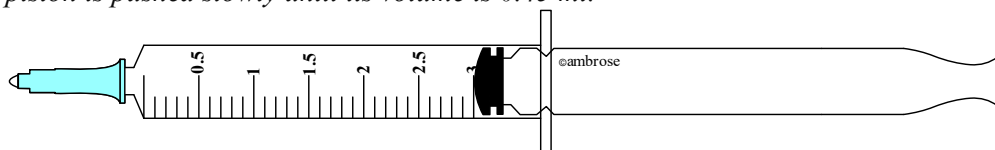

Rajah / Diagram 12.1

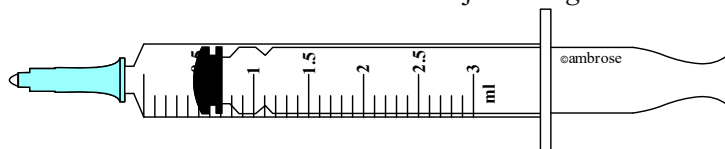

Rajah / Diagram 12.2

Berapakah tekanan udara yang terperangkap?

*What is the pressure of trapped air?*

- A.  $8.0 \times 10^5 \text{ Pa}$
- B.  $7.67 \times 10^5 \text{ Pa}$
- C.  $5.67 \times 10^5 \text{ Pa}$
- D.  $6.67 \times 10^5 \text{ Pa}$



13. Rajah 13 menunjukkan graf sesaran-masa bagi gelombang yang merambat sepanjang seutas tali.

Diagram 13 shows a displacement-time graph for a propagating wave along a piece of rope.

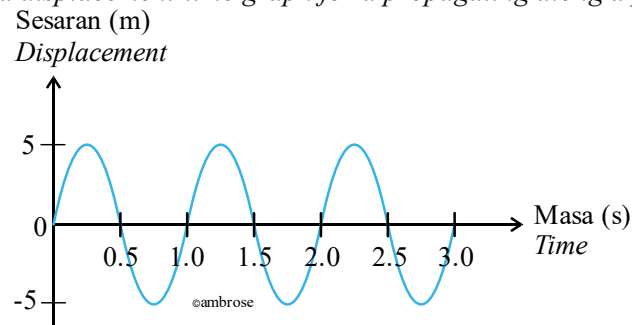

Rajah / Diagram 13

Apakah amplitud dan tempoh bagi gelombang tersebut?

What is the amplitude and period of the wave?

	Amplitud / Amplitude	Tempoh / Period
A.	5	3.0
B.	10	1.0
C.	5	1.0
D.	10	2.0

14. Antara rajah-rajah berikut, yang manakah betul menunjukkan pembiasan gelombang dari udara ke dalam air?

Which of the following diagram shows the correct refraction of wave from air to water?

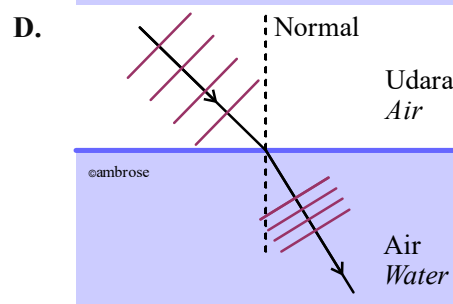
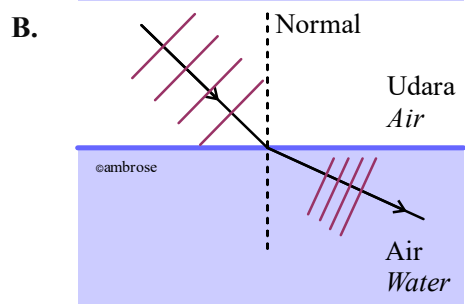
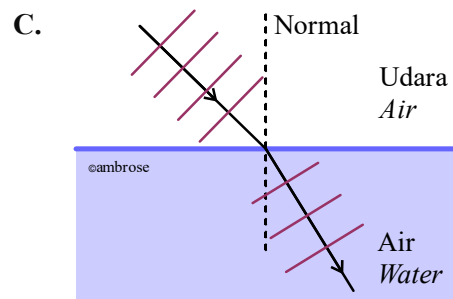
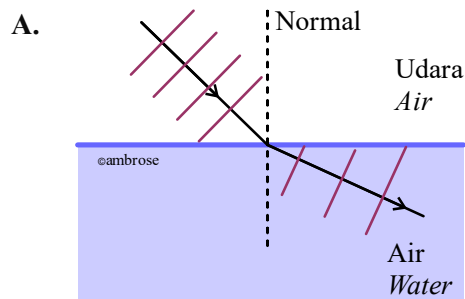

15. Rajah 15 menunjukkan corak cahaya yang terhasil di atas skrin dalam suatu eksperimen.  
Rajah 15 shows patterns of light produced on screen in an experiment.

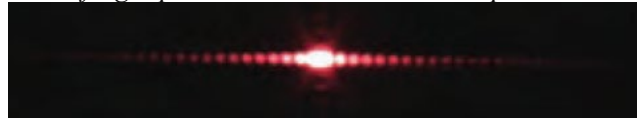

Rajah / Diagram 15

Apakah fenomena yang terlibat?

What is the phenomenon involved?

- A. Pembiasan / Refraction  
B. Pembelauan / Diffraction  
C. Resonans / Resonance  
D. Interferens / Interference
16. Rajah 16 menunjukkan dwicelah Young menghasilkan corak interferens pada skrin. Jarak di antara pinggir merah yang bersebelahan adalah 5.6 mm.  
Diagram 16 shows Young's double slits produces interference patterns on the screen. The distance between consecutive red fringes is 5.6 mm.

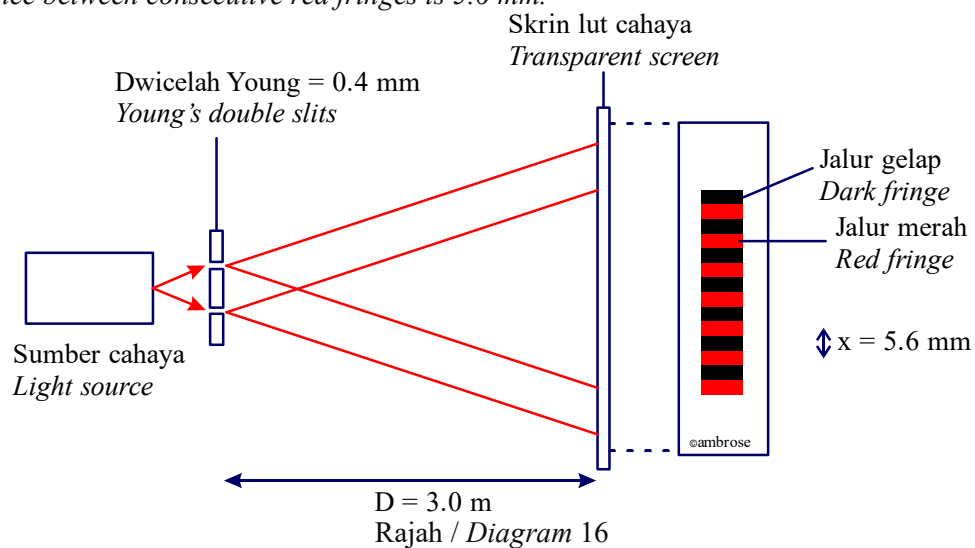

Rajah / Diagram 16

Hitung panjang gelombang cahaya merah.

Calculate wavelength of red light.

- A.  $7.5 \times 10^{-7} \text{ m}$   
B.  $6.0 \times 10^{-7} \text{ m}$   
C.  $6.5 \times 10^{-7} \text{ m}$   
D.  $4.2 \times 10^{-7} \text{ m}$
17. Rajah 17 menunjukkan cahaya dari udara terbias apabila masuk ke dalam air dan perspex. Indeks biasan bagi air dan perspex masing-masing adalah 1.33 dan 1.5.  
Diagram 17 shows a light from air refracted when enter the water and perspex. Refractive index of water and perspex respectively is 1.33 and 1.5.

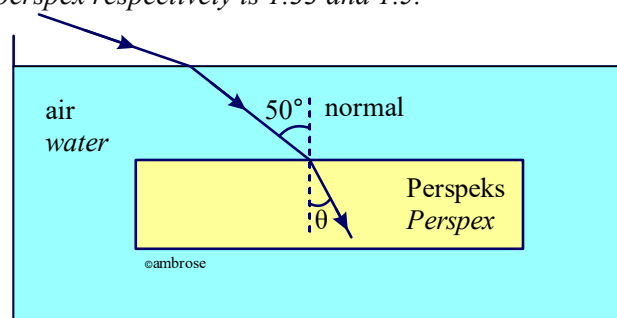

Rajah / Diagram 17

Tentukan sudut,  $\theta$  / Determine the angle,  $\theta$ .

- A.  $30.00^\circ$   
B.  $35.45^\circ$   
C.  $40.27^\circ$   
D.  $42.78^\circ$

18. Rajah 18 menunjukkan imej yang dihasilkan oleh sebuah kanta pembesar.  
 Diagram 18 shows the image formed by a magnifying glass.





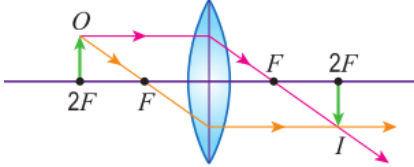
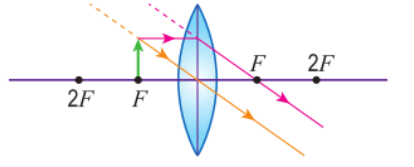
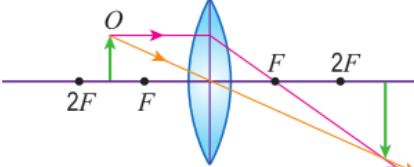
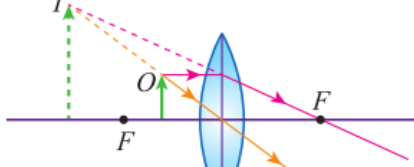

Rajah / Diagram 18

Rajah sinar manakah yang betul menerangkan sifat imej yang terhasil?  
 Which of the following ray diagram is correct to show the characteristics of the image formed?

- A. 
- B. 
- C. 
- D. 

19. Antara rajah berikut yang manakah bukan aplikasi cermin cekung?  
 Which of the following diagram is not the application of concave mirror?

- A.   
 Cermin solek  
 Make up mirror
- B.   
 Pemantul dalam lampu hadapan kereta  
 Reflector in car headlight
- C.   
 Cermin pergigian  
 Dental mirror
- D.   
 Cermin titik buta  
 Blind spot mirror

20. Rajah 20 menunjukkan seorang penumpang berjisim 60 kg berada di dalam sebuah lif.  
*Diagram 20 shows a passenger of mass 60 kg is in a lif.*

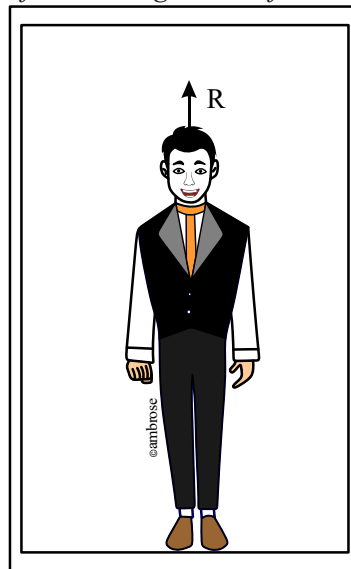

Rajah / Diagram 20

Hitungkan magnitud tindak balas normal,  $R$  apabila lif bergerak ke atas dengan suatu pecutan  $1.5 \text{ m s}^{-2}$ .

*Calculate the magnitude of normal reaction,  $R$  when the lift moving upward with an acceleration  $1.5 \text{ m s}^{-2}$ .*

(Pecutan graviti / Gravitational acceleration,  $g = 9.81 \text{ m s}^{-2}$ )

- A. 498.6 N  
 B. 588.6 N  
 C. 678.6 N  
 D. 700.0 N
21. Rajah 21 menunjukkan sebuah kotak dalam keadaan pegun di atas satah condong.  
*Diagram 21 shows a box in stationary on an inclined plane.*

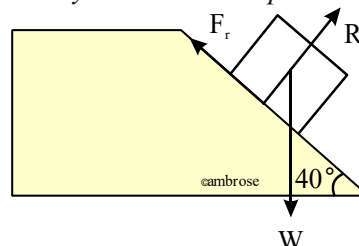

Rajah / Diagram 21

Antara rajah berikut yang manakah mewakili gambar rajah jasad bebas bagi kotak.  
*Which of the following diagram represent the free body diagram for the box?*

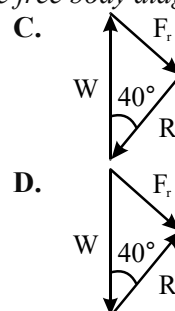
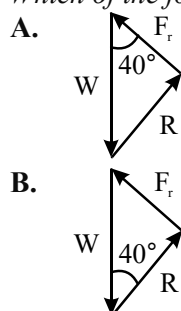

22. Rajah 22 menunjukkan seorang budak bermain permainan kuda berspring di taman permainan kanak-kanak.

*Diagram 22 shows a boy play a horse spring at the playground.*

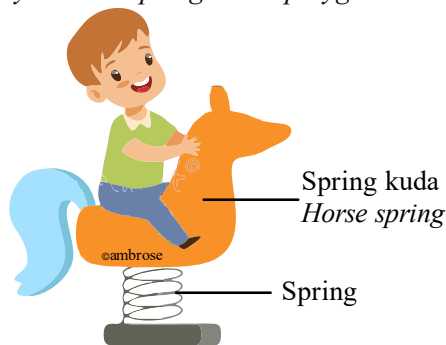

Rajah / Diagram 22

Apakah pengubahsuaian yang harus dilakukan pada spring apabila budak yang lebih berat bermain di atas kuda berspring?

*What modification should be done to the spring when heavier kids play on the horse spring?*

- A. Mengecilkan diameter spring  
*Reduce the diameter of spring*
- B. Menambah diameter dawai spring  
*Increase the diameter of spring wire*
- C. Menambahkan panjang spring  
*Increase the length of spring*
23. Rajah 23 menunjukkan seekor ikan berada pada kedalaman 2.3 m di dalam sebuah akuarium. Ketumpatan air akuarium adalah  $1\,050\text{ kg m}^{-3}$ .

*Diagram 23 shows a fish is at depth 2.3 m in an aquarium. The density of water in the aquarium is  $1\,050\text{ kg m}^{-3}$ .*

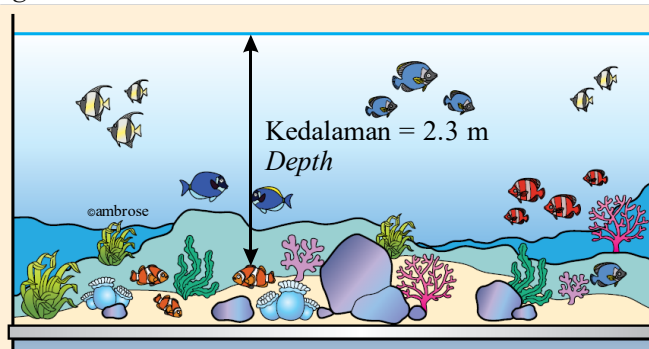

Rajah / Diagram 23

Berapakah tekanan yang dialami oleh ikan itu disebabkan oleh air disekelilingnya?

*What is the pressure experienced by the fish cause by the water around it?*

- A. 22 563 Pa
- B. 24 691 Pa
- C. 23 691 Pa
- D. 24 150 Pa

24. Rajah 24 menunjukkan sistem hidraulik pada brek basikal.  
 Diagram 24 shows hydraulic system for a brake of a bicycle.



Rajah / Diagram 24

Apakah prinsip fizik yang terlibat?  
 What is the physics principle involved?

- |  |  |
|--|--|
| <p>A. Prinsip Pascal<br/>         Pascal's principle</p> <p>B. Prinsip Archimedes<br/>         Archimedes' principle</p> | <p>C. Prinsip Bernoulli<br/>         Bernoulli's principle</p> <p>D. Tekanan cecair<br/>         Liquid pressure</p> |
|--|--|

25. Rajah 25.1 dan Rajah 25.2 menunjukkan kapal yang serupa masing-masing berada dalam air musim sejuk dan air tawar.  
 Diagram 25.1 and Diagram 25.2 shows identical ship in winter water and fresh water respectively.



Rajah / Diagram 25.1



Rajah / Diagram 25.2

Manakah pernyataan berikut adalah benar?  
 Which of the following statement is correct?

- A. Berat air musim sejuk yang tersesar lebih besar daripada berat air tawar yang tersesar.  
 The weight of winter water displaced is greater than the weight of fresh water displaced.
- B. Berat air musim sejuk yang tersesar adalah sama dengan berat air tawar yang tersesar.  
 The weight of winter water displaced is the same with the weight of fresh water displaced.
- C. Berat air musim sejuk yang tersesar lebih kecil daripada berat air tawar yang tersesar.  
 The weight of winter water displaced is smaller than the weight of fresh water displaced.
- D. Isipadu air musim yang tersesar adalah sama dengan isipadu air tawar yang tersesar.  
 The volume of winter water displaced is equal to the volume of fresh water displaced.

26. Rajah 26 menunjukkan graf beza keupayaan melawan arus bagi suatu conductor.  
*Diagram 26 shows a graph of potential difference against current for a conductor.*

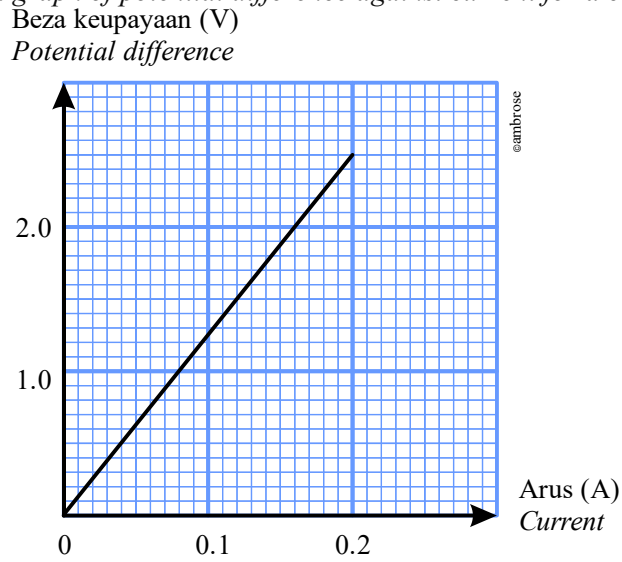

Rajah / Diagram 26

Apakah rintangan bagi konduktor tersebut?

*What is the resistance of the conductor?*

- A. 1.25 Ω
- B. 5.25 Ω
- C. 10.5 Ω
- D. 12.5 Ω

27. Rajah 27 menunjukkan susunan litar elektrik.  
*Diagram 27 shows arrangement of an electric circuit.*

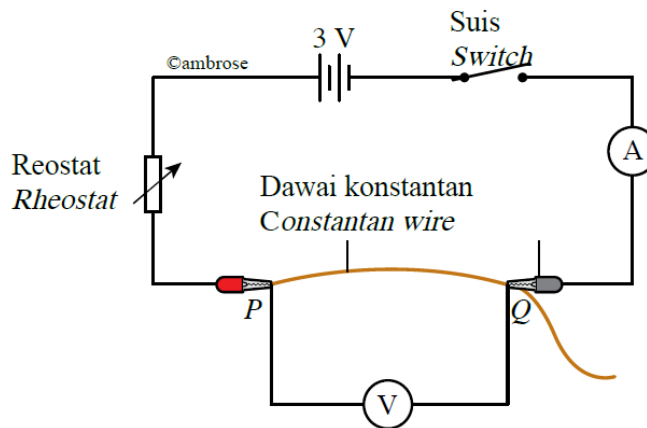

Rajah / Diagram 27

Apakah yang harus dilakukan untuk meningkatkan bacaan voltmeter?

*What should be done to increase the reading of voltmeter?*

- A. Menambah panjang dawai konstantan  
*Increase the length of constantan wire*
- B. Menambah luas keratan rentas dawai konstantan  
*Increase the cross sectional area of constantan wire*
- C. Tukar dawai konstantan dengan dawai kuprum  
*Change constantan wire with copper wire*
- D. Tambah satu dawai konstantan yang serupa secara selari  
*Add another identical constantan wire in parallel*

28. Antara pernyataan berikut yang manakah bukan langkah-langkah penjimatan penggunaan tenaga elektrik di rumah?  
Which of the following statement is not steps in reducing household's electrical energy usage?
- Tutup tingkap dan pintu apabila menggunakan penyaman udara.  
*Close all windows and doors when using the air conditioner*
  - Matikan suis peralatan elektrik jika tidak digunakan.  
*Switch off electrical appliances when they are not in use.*
  - Gunakan mesin basuh dengan muatan penuh sahaja.  
*Use only full loads of laundry when using the washing machine.*
  - Guna lampu jimat kos  
*Use cost saver lamp*
29. Rajah 29 menunjukkan petua tangan kiri Fleming untuk menentukan arah daya.  
Diagram 29 shows Fleming's left-hand rule used to determine the direction of force.

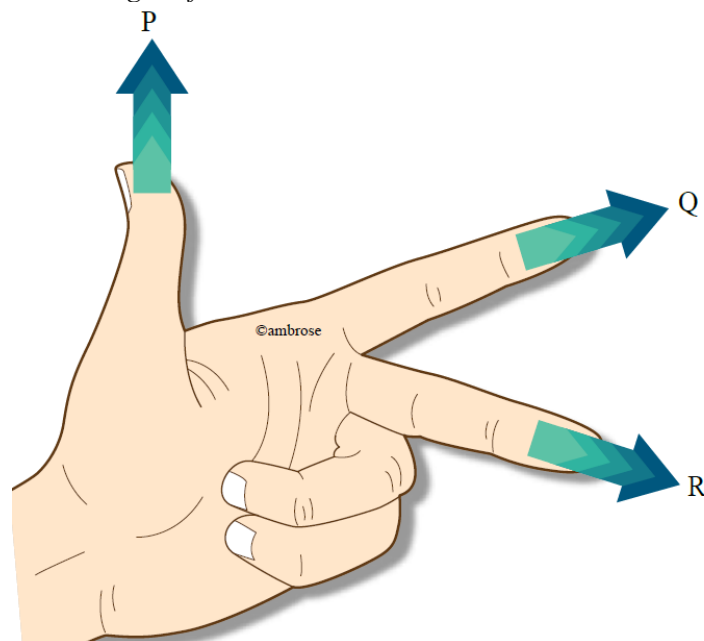

Rajah / Diagram 29

Apakah P, Q, dan R?  
What is P, Q and R?

	P	Q	R
A.	Medan magnet <i>Magnetic field</i>	Daya <i>Force</i>	Arus <i>Current</i>
B.	Daya <i>Force</i>	Medan magnet <i>Magnetic field</i>	Arus <i>Current</i>
C.	Arus <i>Current</i>	Daya <i>Force</i>	Medan magnet <i>Magnetic field</i>
D.	Daya <i>Force</i>	Arus <i>Current</i>	Medan magnet <i>Magnetic field</i>



30. Rajah 30 menunjukkan sebatang rod kuprum memotong fluks magnet.  
 Diagram 30 shows a copper rod cut magnetic flux.

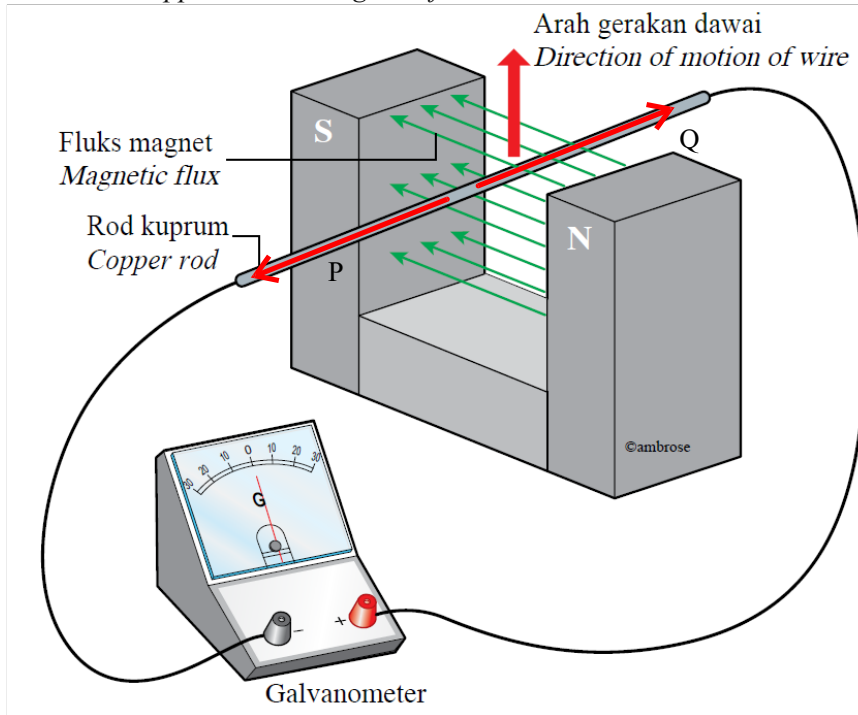

Rajah / Diagram 30

Pasangan manakah yang betul menunjukkan arah gerakan arus aruhan dan arah pesongan penunjuk galvanometer?

Which of the following pair is correct to show the direction of induced current and direction of deflection of pointer in galvanometer?

	Arah arus aruhan <i>Direction of induced current</i>	Arah pesongan penunjuk galvanometer <i>Direction of deflection of pointer of galvanometer</i>
A.	P	Kiri / Left
B.	Q	Kanan / Right
C.	P	Kanan / Right
D.	Q	Kiri / Left

31. Rajah 31 menunjukkan sebuah transformer unggul.

Diagram 31 shows an ideal transformer.

Primary coil = 2000 turns

Gegelung primer = 2000 lilitan

Secondary coil = 500 turns

Gegelung sekunder = 500 lilitan

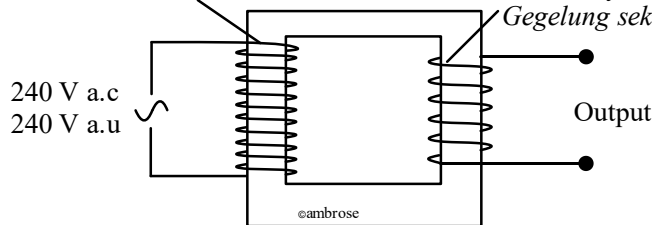

Rajah / Diagram 31

Apakah voltan output?

What is the output voltage?

- A. 60 V
- B. 120 V
- C. 240 V
- D. 520 V

32. Rajah 32 menunjukkan alur elektron dihasilkan daripada permukaan katod.  
 Diagram 32 shows an electron beam produced from the surface of cathode.

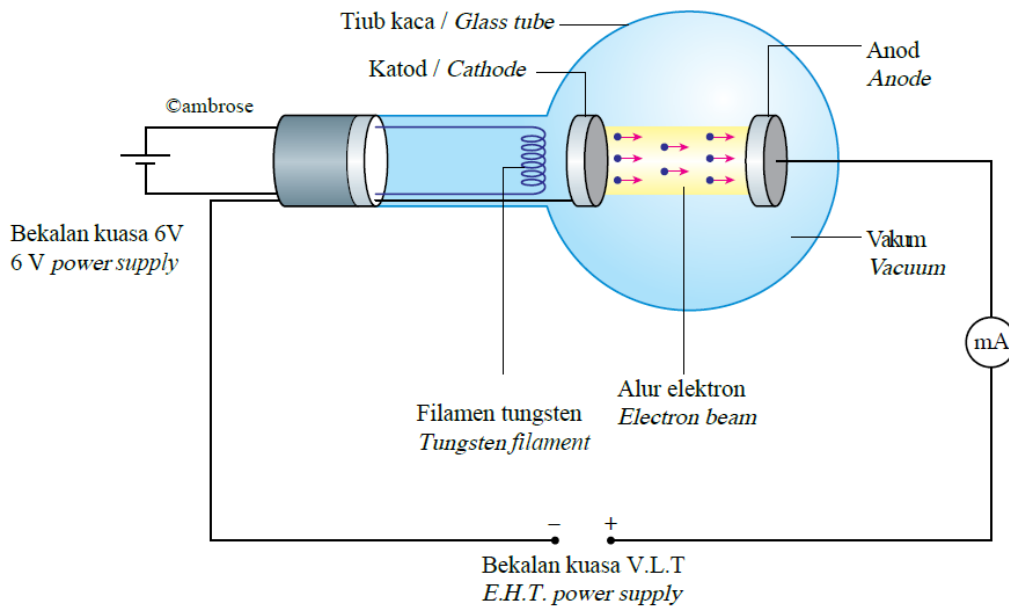

Rajah / Diagram 32

Namakan proses yang terlibat.

Name the process involve.

- |   |  |
|---|--|
| A. Penyejatan elektron<br><i>Electron evaporation</i> | C. Kesan fotoelektrik<br><i>Photoelectric effect</i> |
| B. Pendopan / <i>Doping</i>                           | D. Pancaran termion / <i>Thermionic emission</i>     |

33. Rajah 33 menunjukkan sambungan diod dalam satu litar yang ringkas.  
 Diagram 33 shows connection of a diode in a simple circuit.

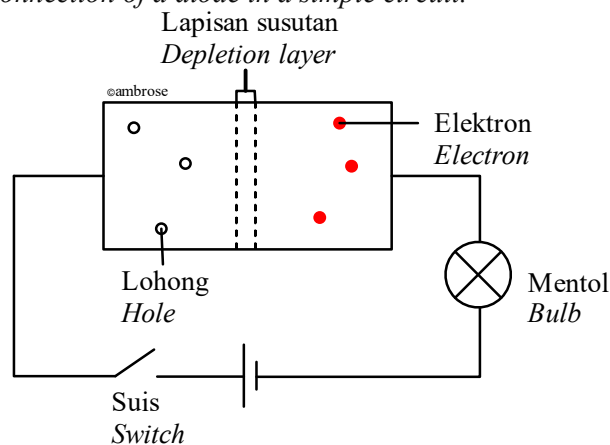

Rajah / Diagram 33

Antara pernyataan berikut yang manakah adalah benar apabila suis dihidupkan?  
 Which of the following statement is correct when the switch is on?

- A. Mentol tidak menyala  
*The bulb is not light up*
- B. Sambungan diod adalah pincang songsang  
*Connection of diode is reverse biased*
- C. Lapisan susutan akan menjadi besar  
*Depletion region will getting larger*
- D. Arus mengalir di dalam litar  
*Current flow in the circuit*

34. Rajah 34 menunjukkan litar penggera kawalan suhu. Beza keupayaan merentasi XY mestilah sekkurang-kurangnya 4.5 V untuk menyalakan mentol 6 V.  
 Diagram 34 shows a temperature-controlled alarm circuit. The potential difference across XY must be at least 4.5 V to turn on the 6 V bulb.

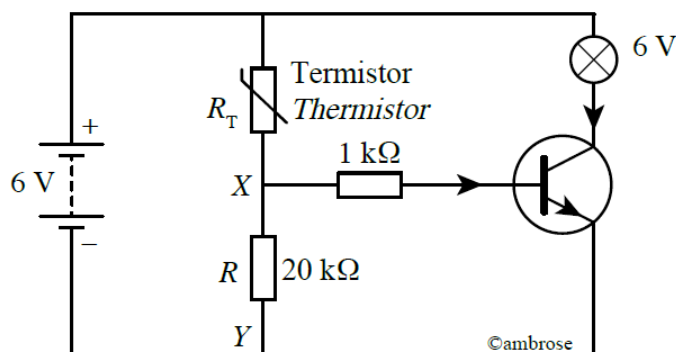

Rajah / Diagram 34

- Berapakah rintangan termistor,  $R_T$  apabila mentol itu menyala?  
 What is the resistance of thermistor,  $R_T$  when the bulb is light up?  
 A. 5.0 kΩ                                  C. 7.4 kΩ  
 B. 6.7 kΩ                                  D. 8.1 kΩ

35. Antara persamaan berikut yang manakah menunjukkan pereputan alfa?  
 Which of the following equation shows alpha decay?

- A.  $^{235}_{92}U + {}^1_0n \rightarrow ^{141}_{56}Ba + ^{92}_{36}Kr + 3 {}^1_0n$   
 B.  $^{24}_{11}Na \rightarrow ^{24}_{12}Mg + {}^0_{-1}e$   
 C.  $^{60}_{27}Co \rightarrow ^{60}_{27}Co + \gamma$   
 D.  $^{210}_{84}Po \rightarrow ^{206}_{82}Pb + {}^4_2He$

36. Rajah 36 menunjukkan graf lengkungan bagi reputan radioaktif bagi suatu bahan.  
 Diagram 36 shows a curve graph for radioactive decay for a substance.

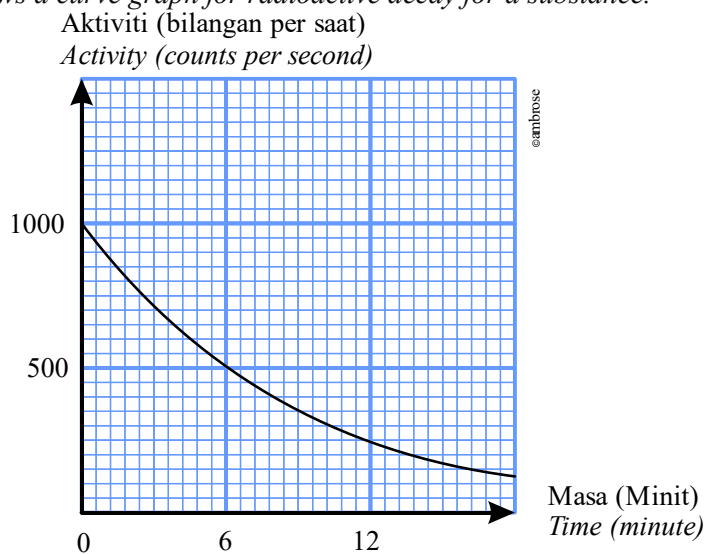

Rajah / Diagram 36

- Apakah aktiviti sampel selepas 30 minit?  
 What is the activity of the sampel after 30 minutes?  
 A. 31.25                                      C. 125.00  
 B. 62.50                                      D. 250.00

37. Rajah 37 menunjukkan suatu tindak balas nuclear di antara bahan radioaktif.  
Diagram 37 shows a nuclear reaction between radioactive substance.

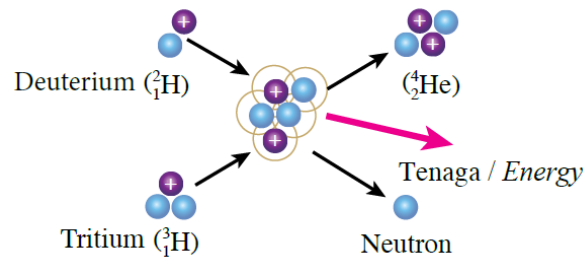

Rajah / Diagram 37

Apakah jenis tindak balas ini?

*What is the type of the reaction?*

- |   |   |
|---|---|
| <p><b>A.</b> Tindak balas berantai<br/><i>Chain reaction</i></p> <p><b>B.</b> Pereputan alfa<br/><i>Alpha decay</i></p> | <p><b>C.</b> Pembelahan nukleus<br/><i>Nuclear fission</i></p> <p><b>D.</b> Pelakuran nukleus<br/><i>Nuclear fusion</i></p> |
|---|---|
38. Apakah sumbangan Albert Einstein dalam Fizik kuantum?  
*What is the contribution of Albert Einstein in Quantum Physics?*
- A.** Memperkenalkan idea kuantum  
*Introduced the concept of quantum*
- B.** Memperkenalkan konsep foton  
*Introduced the concept of photon*
- C.** Menerangkan penghasilan spektrum garis  
*Explained the production of line spectrum*
- D.** Memperkenalkan zarah juga bersifat gelombang  
*Introduced the wave nature of particles*
39. Antara pernyataan berikut yang manakah bukan ciri-ciri kesan fotoelektrik?  
*Which of the following statement is not characteristics of photoelectric effect?*
- A.** Keamatan cahaya mempengaruhi tenaga fotoelektron  
*Intensity of light affects the energy of photoelectron*
- B.** Semakin tinggi frekuensi foton, semakin bertambah tenaga kinetik maksimum fotoelektron  
*The greater the frequency of photons, the greater the maximum kinetic energy of photoelectrons*
- C.** Pengeluaran elektron daripada permukaan logam berlaku secara serta-merta  
*The emission of electrons from the surface of metal is occurred instantaneously*
- D.** Frekuensi minimum yang dikenali sebagai frekuensi ambang diperlukan untuk mengeluarkan elektron  
*Minimum frequency known as threshold frequency is required to emit the electrons*
40. Logam kalsium mempunyai fungsi kerja 3.00 eV. Berapakah tenaga kinetik maksimum photoelektron apabila disinari dengan cahaya ungu ( $\lambda = 380\text{nm}$ )?  
*Calcium metal has work function 3.00 eV. What is the maximum kinetic energy possessed by the electrons when irradiated with violet light ( $\lambda = 380\text{nm}$ )?*
- |   |   |
|---|---|
| <p><b>A.</b> 0.27 eV</p> <p><b>B.</b> 0.52 eV</p> | <p><b>C.</b> 0.72 eV</p> <p><b>D.</b> 1.05 eV</p> |
|---|---|